

CILINDRO DE FRENO  
BRAKE CYLINDER  
BREMSZYLINDER

**BASTIMEC®**  
hydraulics

**SERIE 700**

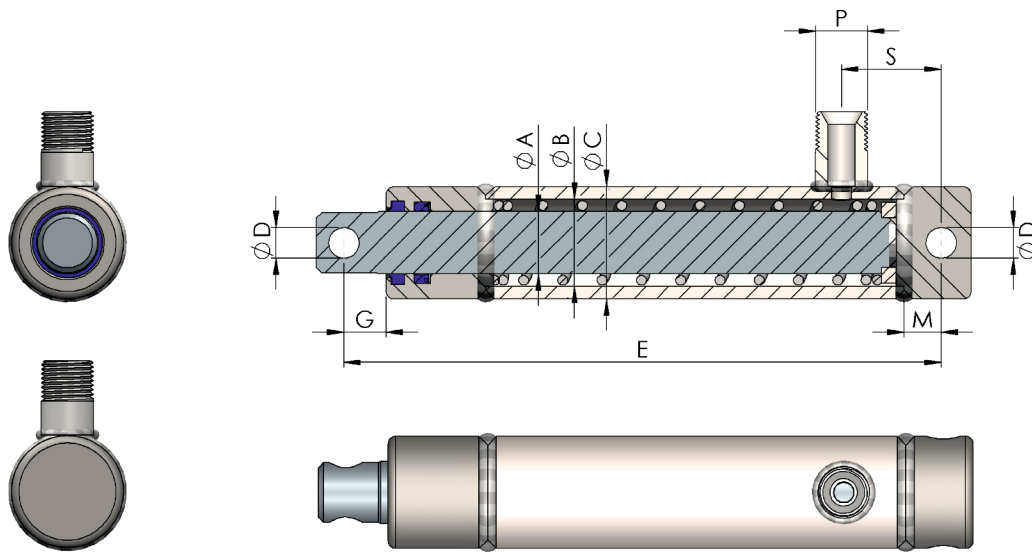

Código Code Bestell-Nr.	ØA	ØB	ØC	Carrera Stroke Hub	E	P (BSP)	ØD	S	G	M	Vol. (lit)	Kgs.
700_010	25	35	45	100±3	240	G1/2	12.25	40	17	15	0,17	0,95

Unidades en milímetros.  
Units in millimeters.  
Einheiten in Millimetern.

**OPCIÓN //OPTION// MÖGLICHKEIT**

**NEW**

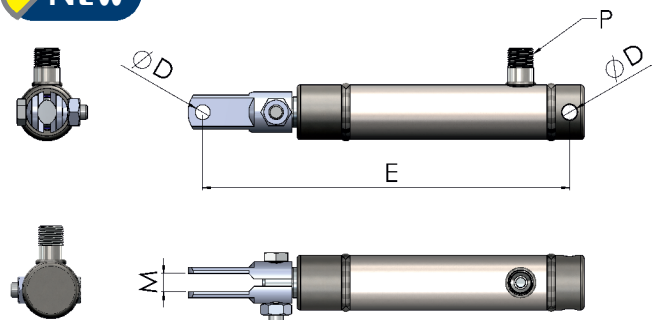

Código Code Bestell-Nr.	P	Carrera Stroke Hub	E	ØD	Kgs.
710_010	G1/2	100±3	300	12.25	1,10

Unidades en milímetros.  
Units in millimeters.  
Einheiten in Millimetern.

Funcionamiento y características:

- \*Retorno por muelle.
- \*Gran resistencia al desgaste.
- \* Juntas en poliuretano 93 Shores.
- \*Testados 100 %.

Performance and features :

- \* Spring return.
- \* High resistance.
- \* Seals Polyurethane 93 Shores.
- \* Tested 100% .

Leistung und Funktionen :

- \* Federrücklauf .
- \* Hohe Verschleißfestigkeit.
- \* Dichtungen Polyurethan 93 Shores .
- \* Geprüft 100% .



Hydraulic seals by  
Aston seals



Velocidad máxima - Max. speed - Höchstgeschwindigkeit : 0,5 m/s.  
Temperatura C° - Temperature C° - Temperaturbereich C° : -25°C - +80°C.  
Presión máxima - Max. pressure - Max. Druck : 250 bars.