

**SERIE 500**

CILINDRO DOBLE EFECTO  
DOUBLE ACTING CYLINDER  
DOPPELWIRKENDE ZYLINDER

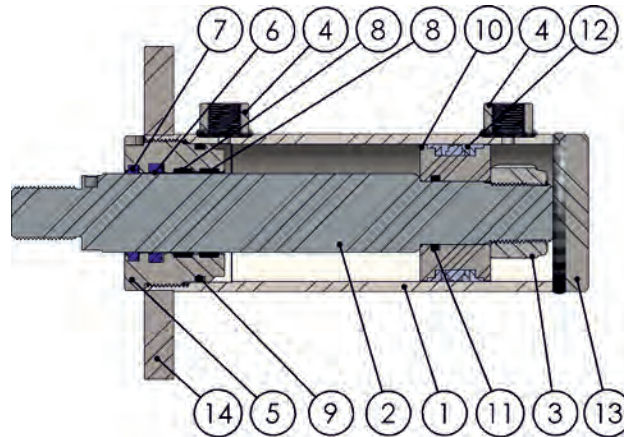

Nº pieza Part No. Part No.	Descripción Description Beschreibung	Material Material Material
1	Tubo lapeado/Cold drawn tube/Poliertes zylinderrohr	Acero - Steel - Stahl St52.3 DIN2353 h9
2	Barra cromada/Chromed rod/Verchromte kolbenstange	Acero - Steel - Stahl C45 Micron ±5 Rating 9/120h
3	Tuerca autoblocante/Lock nut/Nut	Grado - Grade - Material 8.8
4	Racor alimentación/Threaded port/Anschlussgewinde	Acero - Steel - Stahl St52.3
5	Cabeza guía D.E./D.A. bush/Kolbenstangenführung	Acero - Steel - Stahl St52.3
6	Collarín CDL/CDL rod seal/Stangendichtungen typ CDL	Poliuretano - Polyurethane - Polyrethan 93 shores
7	Rascador/Wiper/Abstreifer	Poliuretano - Polyurethane - Polyrethan 93 shores
8	Guía/guide/Führungsring	Resina acetal - Acetal resine - Polyacetal
9	Junta tórica/O-ring/O-ringe	NBR
10	Pistón OTD/OTD piston/Kolben OTD	Acero - Steel - Stahl St52.3
11	Junta tórica/O-ring/O-ringe	NBR
12	Junta pistón DAS/DAS piston seal/Kolben DAS	NBR+ POM
13	Fondo/End plug/Zylinderboden	Acero - Steel - Stahl St52.3
14	Brida/Flange/Flansch	Acero - Steel - Stahl St52.3

Velocidad máxima - Max. speed - Höchstgeschwindigkeit : 0,5 m/s.  
Temperatura C° - Temperature C° - Temperaturbereich C° : -25°C - +80°C.  
Presión máxima - Max. pressure - Max. Druck : 250 bars.

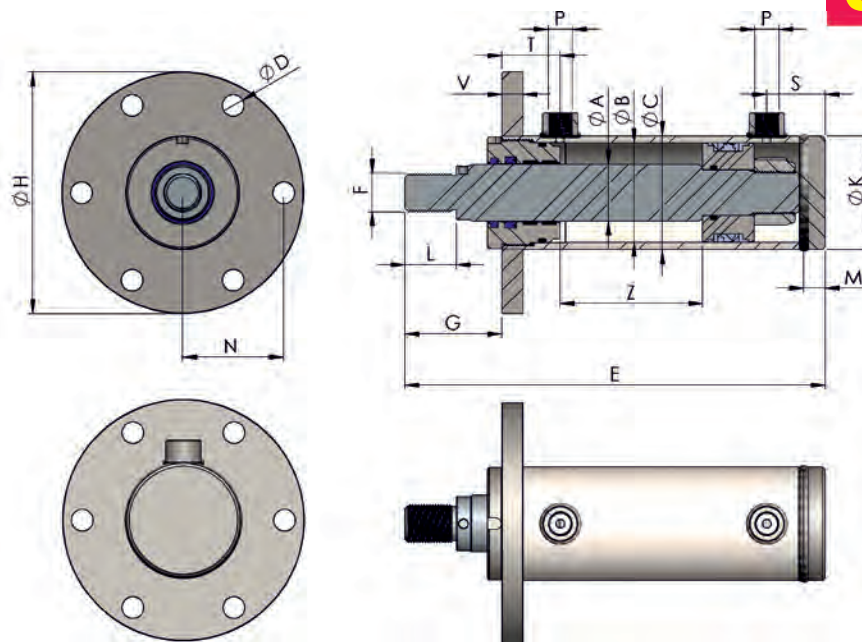

Código Code Bestell-Nr.	ØA	ØB	ØC	Z	E	ØD	P (BSP)	S	T	N	V	ØH	G	L	F	ØK	M	Kit juntas Seals kit Dichtsätze	Vol. (lit)	Kgs.
500_010	20	32	40	100	220	7	G1/4	26	25	33,5	10	80	39	18	M14X1.5	40	10	KJDE032040020	0,08	1,70
500_020				200	320														0,16	2,30
500_030				300	420														0,24	2,90
500_040				400	520														0,32	3,50
500_050				500	620														0,40	4,10
500_060				600	720														0,48	4,70
500_070				700	820														0,56	5,30
501_010				25	40														50	100
501_020	200	355	0,25			4,05														
501_030	300	455	0,38			5,00														
501_040	400	555	0,50			5,95														
501_050	500	655	0,63			6,90														
501_060	600	755	0,75			7,85														
501_070	700	855	0,88			8,80														
502_010	30	50	60			100	270	11	G3/8	35	35	51,5	12	125	55	28	M20X1.5	60		15
502_020				200	370	0,39	5,75													
502_030				300	470	0,59	7,00													
502_040				400	570	0,79	8,25													
502_050				500	670	0,98	9,50													
502_060				600	770	1,18	10,75													
502_070				700	870	1,37	12,00													
503_010				30	60	70	100												280	
503_020	200	380	0,57				7,15													
503_030	300	480	0,85				8,50													
503_040	400	580	1,13				9,85													
503_050	500	680	1,41				11,20													
503_060	600	780	1,70				12,55													
503_070	700	880	1,98				13,90													

Unidades en milímetros.  
Units in millimeters.  
Einheiten in Millimetern.

CILINDRO DOBLE EFECTO  
DOUBLE ACTING CYLINDER  
DOPPEL WIRKENDE ZYLINDER

**SERIE 500**

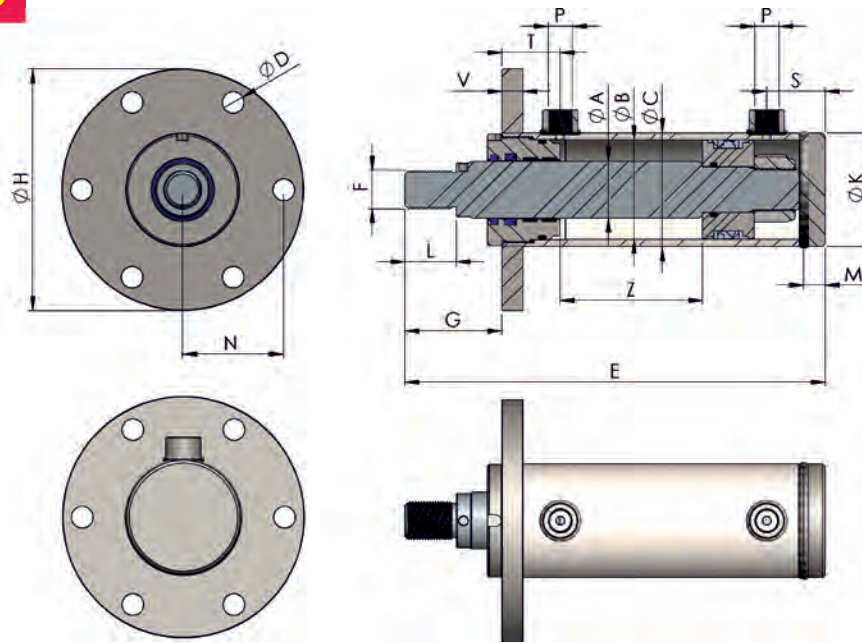

Código Code Bestell-Nr.	ØA	ØB	ØC	Z	E	ØD	P (BSP)	S	T	N	V	ØH	G	L	F	ØK	M	Kit juntas Seals kit Dichtsätze	Vol. (lit)	Kgs.
504_010	40	70	80	100	295	15	G3/8	41	41	71	15	170	68	36	M27X2.0	80	15	KJDE070080040	0,39	8,65
504_020				200	395														0,77	10,55
504_030				300	495														1,15	12,45
504_040				400	595														1,54	14,35
504_050				500	695														1,92	16,25
504_060				600	795														2,31	18,15
504_070				700	895														2,69	20,05
505_010				40	80														90	100
505_020	200	410	1,01			12,50														
505_030	300	510	1,51			14,50														
505_040	400	610	2,01			16,50														
505_050	500	710	2,51			18,50														
505_060	600	810	3,01			20,50														
505_070	700	910	3,51			22,50														
506_010	50	90	100			100	320	17	G3/8	41	50	85	15	202	76	45	M33X2.0	100		15
506_020				200	420	1,27	5,70													
506_030				300	520	1,91	6,90													
506_040				400	620	2,54	8,10													
506_050				500	720	3,18	9,30													
506_060				600	820	3,82	10,50													
506_070				700	920	4,45	11,70													
507_010				50	100	115	100												340	
507_020	200	440	1,57				23,20													
507_030	300	540	2,36				26,70													
507_040	400	640	3,14				30,20													
507_050	500	740	3,93				33,70													
507_060	600	840	4,71				37,20													
507_070	700	940	5,50				40,70													

Unidades en milímetros.  
Units in millimeters.  
Einheiten in Millimetern.

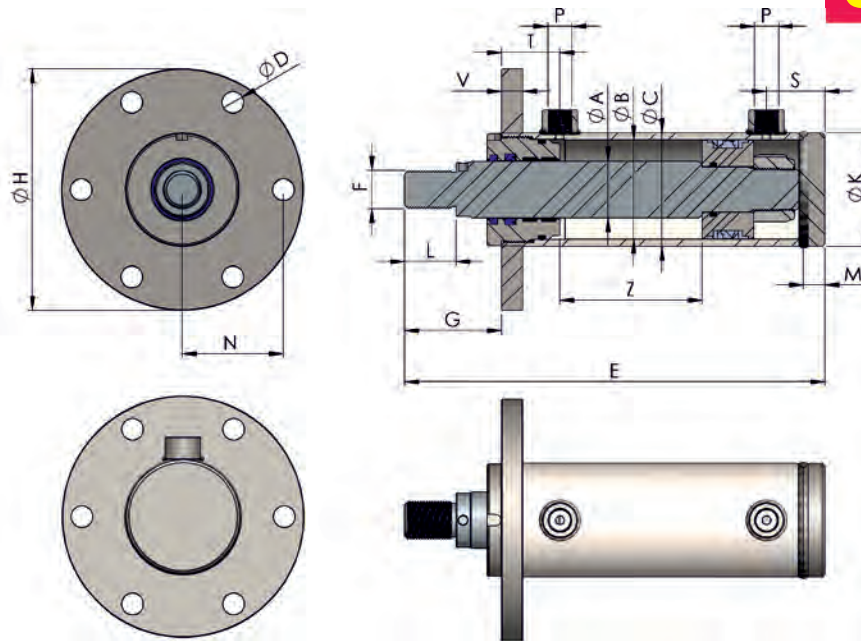

Código Code Bestell-Nr.	ØA	ØB	ØC	Z	E	ØD	P (BSP)	S	T	N	V	ØH	G	L	F	ØK	M	Kit juntas Seals kit Dichtsätze	Vol. (lit)	Kgs.
508_010	70	120	140	100	370	21	G1/2	50	53	105	30	250	103	63	M48X2.0	140	20	KJDE120140070	1,13	32,90
508_020				200	470														2,26	39,10
508_030				300	570														3,39	45,30
508_040				400	670														4,52	51,50
508_050				500	770														5,65	57,70
508_060				600	870														6,78	63,90
508_070				700	970														7,91	70,10
509_010	80	130	150	100	410	21	G3/4	50	60	115	30	280	121	85	M64X2.0	150	20	KJDE130150080	1,33	43,15
509_020				200	510														2,65	50,50
509_030				300	610														3,98	57,85
509_040				400	710														5,31	65,20
509_050				500	810														6,63	72,55
509_060				600	910														7,96	79,90
509_070				700	1010														9,29	87,25

Unidades en milímetros.  
Units in millimeters.  
Einheiten in Millimetern.

**JUNTAS // SEALS // DICHTSÄTZE**

Hydraulic seals by  
Aston seals



Para trabajos de alta intensidad y alta presión, contacte con nuestro departamento técnico.  
For works of high intensity and high pressure, contact our technical department.  
Für Werke von hoher Intensität und hohem Druck, mit unserer technischen Abteilung.